

BRIDGEPORT V1000

VERTICAL MACHINING CENTER



 **HARDINGE**[®]

Bridgeport[®]

BRIDGEPORT V1000

VERTICAL MACHINING CENTER



HARDINGE PRECISION SPINDLE

- Dual contact, 40 taper, 10,000-rpm grease lubricated spindle powered by a direct drive, dual-wound Fanuc spindle motor. Optional Siemens spindle motor is also available.

- Optional 12,000-rpm / 15,000-rpm Oil-Air Spindle.

- High tool retention for aggressive cutting applications. (900kgf / 8,820N)

BIG-Plus dual contact spindle that provides a stiffer interface between the spindle and the tool holder along with minimum run out on extended tools and better overall repeatability.

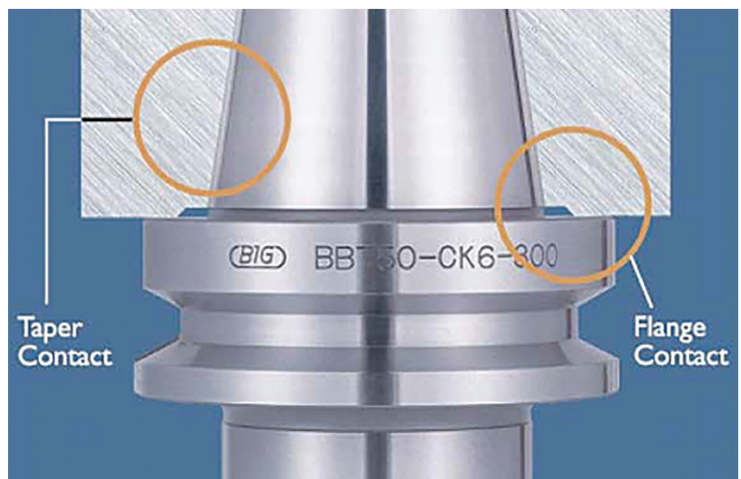

VERTICAL MACHINING CENTER

HIGH RIGIDITY STRUCTURE

The ATC mount is designed to properly support the ATC's weight by putting the force directly into the column for superior stability, rigidity and minimized vibration to the cutting zone.

- The Z & Y-axis utilizes 45mm ball-guides. The Z-axis features (3) trucks per guideway and the Y-axis, (2) trucks per guideway. The X-axis features (2) 35mm ball-guides with (2) trucks per guideway.

- This heavy duty guideway system ensures a very stiff, rigid and durable machine providing years of low maintenance, high accuracy and superior surface finishes.

- Robust "C-frame" fixed column design from the popular XR machine family.
- Strategically ribbed base, column, and spindle carrier for increased rigidity and stiffness during demanding machining applications.
- Includes scraping of column & base joint for improved overall stiffness and rigidity.

TOOL PROBE (OPTIONAL)

Automatic Renishaw Tool Probe, easy to use and define tool offset combined with marco programming Reduce non-cutting cycle time and easily check tool length, diameter or wear.

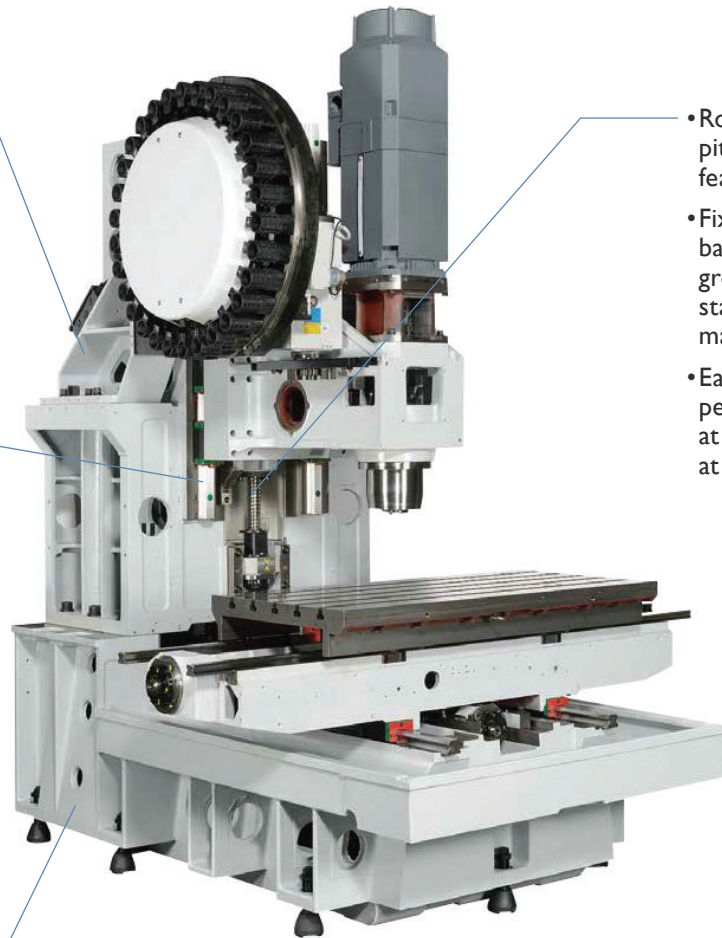

- Robust class #3, 45mm, 12mm pitch, double-nut ballscrews are featured in the X, Y and Z-axis.
- Fixed, pre-tensioned (0.04mm) ballscrews minimize thermal growth, enhance rigidity, stability, and precision of the machine.
- Each axis features (5) bearings per ballscrew. (3) bearings/set at motor side, (2) bearings/set at end side.

MACHINE LUBRICATION

VI1000 utilizes Manual Centralized Grease Lubrication for all ballscrews and linear guides for extended component life. Optional Auto Grease Lubrication is also available.

MACHINE LUBRICATION UNIT



AUTOMATIC LUBRICATION (OPTION)



CONTROLS



FANUC OIMF CONTROL FEATURES:

- 10.4" LCD Color Display
- Linear / Circular / Helical Interpolation
- Programmable Data Input
- PCMCIA Card Slot
- Workpiece Coordinate System
- Manual Pulse Generator (Handwheel)
- Coordinate System Rotation
- Rigid Tapping
- Tool Life Management
- Tool Length compensation
- Background Editing
- Ethernet Ready / RS232 Ready/ USB Slot
- Additional Workpiece
- Coordinate System
- Manual Guide i



HEIDENHAIN 620 CONTROL FEATURES:

- Contour Approach and Departure
- FK Free Contour Programming
- Program Jumps
- Fixed Cycles
- Coordinate Transformations
- Q Parameters
- Programming Aids
- Actual Position Capture
- Verification Graphics
- Program Run Graphics
- Machining Time
- Returning to the Contour
- Datum Tables
- Preset Table
- Data Interfaces
- Tool Compensation
- Cutting Data Tables
- Constant Contouring Speed
- Parallel Operation



SIEMENS 828D CONTROL FEATURES:

- 10.4" Color Display
- RJ45 Ethernet Port / Network Drive
- USB 2.0
- Compact Flash (CF) interface
- Intuitive Jog Mode
- Tool and Workpiece Measurement
- Intuitive & Transparent Tool Management
- Graphical Interactive Programming & Operation
- Mold Making Quick Viewer
- Transformation - Cycle800
- MDynamics - Mold & Die
- Technology Package

Conversational programming features offered on the CNC control is the CNC control builder's standard product, which may not fully support all machine functions. It is recommended the end user reference the control system documentation, or contact the control manufacturer, for further details of use or customization.

VERTICAL MACHINING CENTER

ATC TOOL MAGAZINE WITH INVERTER

Taper (ISO No.): 40

Tool Holder Type: BT or CAT or ANSI
or DIN (SK)

PULL STUD TYPE:

1. BT or modified BT for CAT & ANSI
2. DIN

- Tool Capacity: 30
- Maximum Tool Diameter (Full Drum): 75 mm
- Max. Tool Diameter (Adj. Pockets Empty): 150mm
- Maximum Tool Length: 300 mm
- Maximum Tool Weight: 7 Kg
- Tool Change Time (T-T): 1.5 Sec

THERE ARE 5 FEATURES WITH THE INVERTER TYPE CAM BOX:

1. Higher speed tool change.
2. Decelerate: Swing arm decelerate before it hits the tool.
3. Support bigger dia. tool and heavy tool change.
4. Arm C.W. and C.C.W. jog operation.
5. Auto recovery.

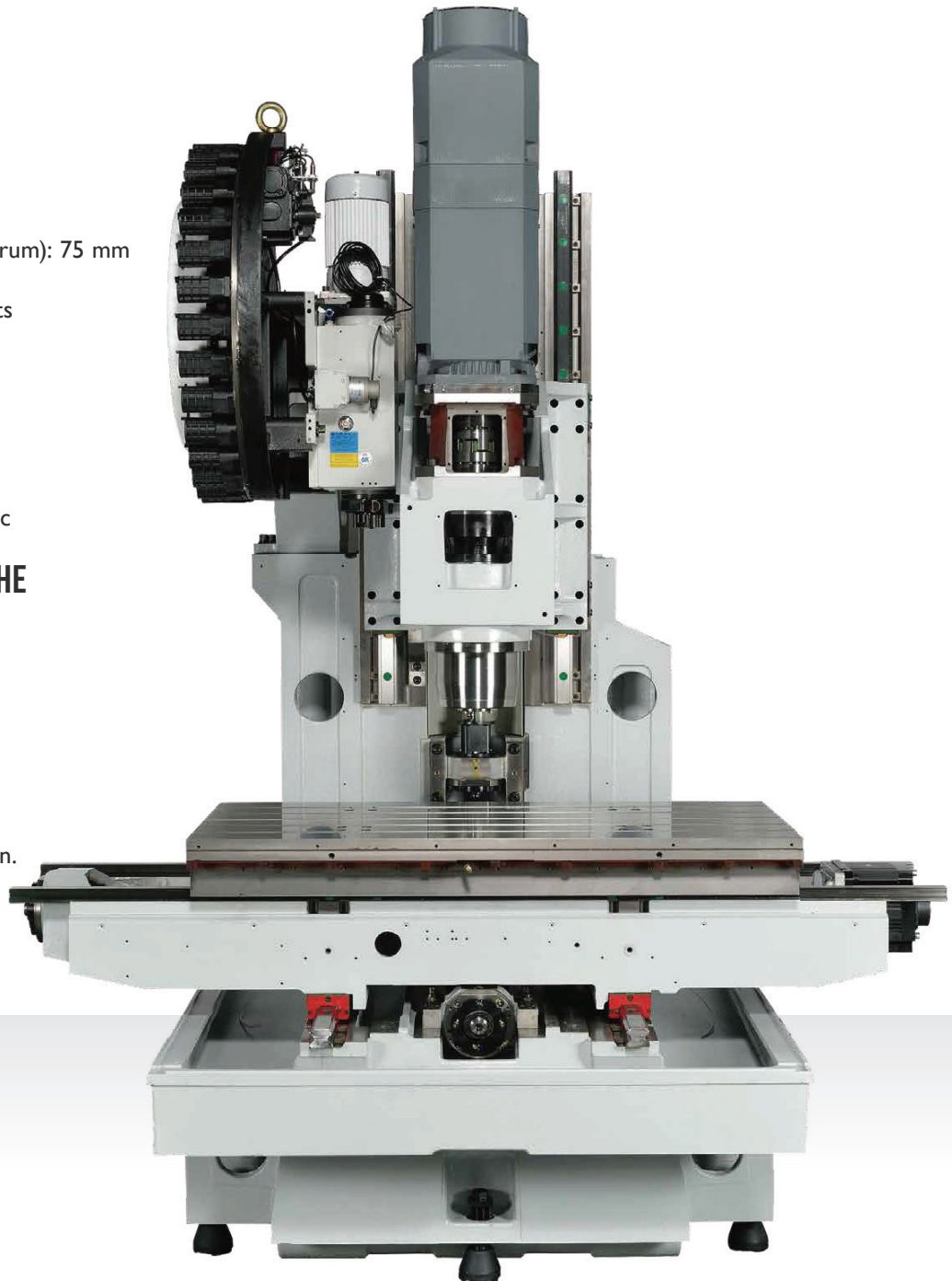

BRIDGEPORT V1000

FANUC SPINDLE MOTOR: 10,000RPM POWER & TORQUE CHARACTERISTIC CURVE:

LOW-SPEED WINDING

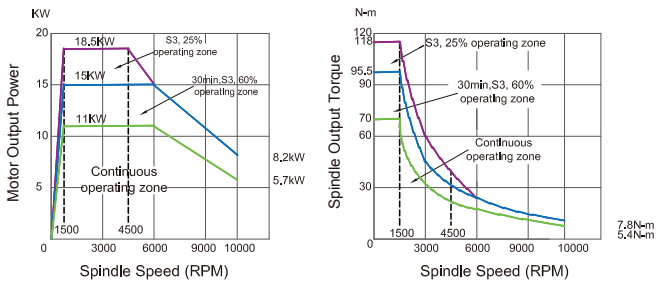

Fanuc iL12/ 12000rpm Spindle Motor
(Speed Limit 10,000rpm)

HIGH-SPEED WINDING

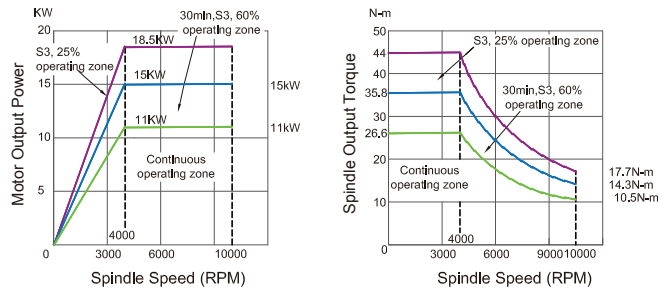

Fanuc iL12/ 12000rpm Spindle Motor
(Speed Limit 10,000rpm)

SIEMENS SPINDLE MOTOR: 10,000RPM POWER & TORQUE CHARACTERISTIC CURVE:

LOW-SPEED WINDING

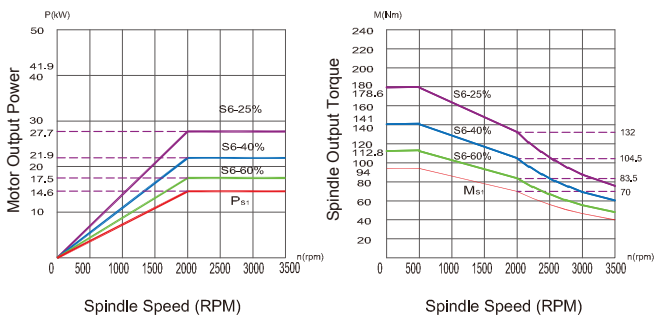

Siemens IPH8131/ 15000rpm Spindle Motor
(Speed Limit 10000rpm)

HIGH-SPEED WINDING

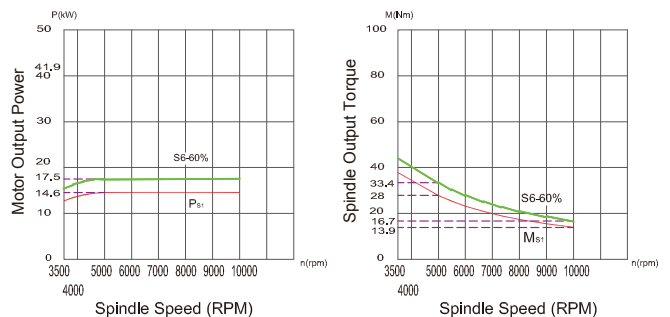

Siemens IPH8131/ 15000rpm Spindle Motor
(Speed Limit 10000rpm)

FLOORPLAN

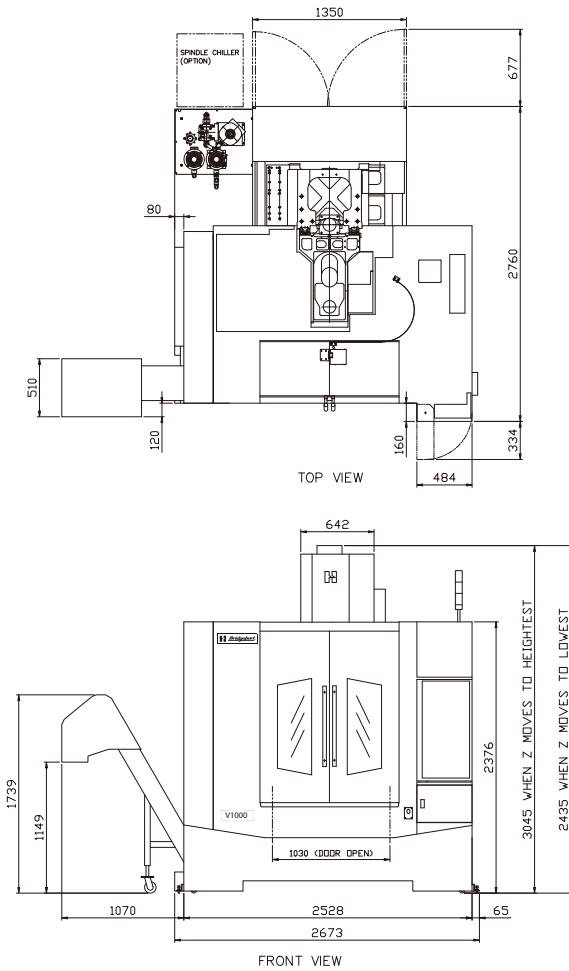

To keep improvements and developing new functions, Hardinge Taiwan reserves the rights to change specifications without further notice.

Due to varying cutting conditions, actual results may be greater or less than those listed

MACHINE SPECIFICATIONS

TRAVEL	
X/Y/Z Axes	1020 x 610 x 610
Spindle Nose to Table	100 - 710
Y-Throat Distance	628
TABLE	
Table Size	1200 x 600
Load Capacity	900 Kg
Distance from Floor to Table Surface	861
SPINDLE	
Taper	BBT 40
Transmission	DDS
Spindle Speed (rpm)	STD: 10,000 (Grease) OPT: 12,000 (Oil-Air)
Motor Power	11 kW/ 18.5kW (Cont./ S3-25%) (Fanuc) 10 kW/ 17kW (S1/ S6-25%) (Heidenhain) 14.6kW/17.5kW (Cont./ S6-60%) (Siemens)
Maximum Torque at Base Speed	36N-m/ 95N-m (Cont./ 30min) (Fanuc) 63.7N-m/ 108.6N-m (S1/ S6-25%) (Heidenhain) 42N-m/ 112N-m (Cont./ S6-60%) (Siemens)
AXES DRIVES (X/Y/Z SERVO MOTORS)	
Fanuc	3kW/ 3kW/ 4kW
Heidenhain	4.5kW/ 4.5kW/ 5.1kW
Siemens	3.1kW/ 3.1kW/ 4.9kW
BALL SCREWS (X/Y/Z AXES)	
Size	45 / 45 / 45
Pitch	X/Y : 16, Z : 12
Lubrication	Grease Central Lubrication
LINEAR GUIDEWAYS (X/Y/Z AXES)	
Type	Ball Guide
Size	35 / 45 / 45
Linear Ways	2 / 2 / 2
Linear Guide Trucks	4 / 4 / 6
Lubrication	Grease Central Lubrication
Rapid Traverse Rate	X/Y: 43m/min, Z: 36m/min
ACCURACY (X/Y/Z AXES)	
Positioning	0.01 (With Scales : 0.005)
Repeatability	0.005 (With Scales : 0.004)
GENERAL SPECIFICATION	
Machine Overall Size (Width / Depth / Height)	2673 x 2760 x 2435~3045
Machine Weight	7000Kg
Front Door Opening	1030
Vision Window Material	Laminated
Coolant Tank Capacity	300
Air Requirement	5.5 kg/cm ² minimum
Power Requirement	89 amp/ 220 volt/ 3 phase (Fanuc) 41 amp/ 400 volt/ 3 phase (Heidenhain) 51 amp/ 400 volt/ 3 phase (Siemens)

STANDARD FEATURES

- Manual Central Grease Lubrication (X/Y/Z Axes)
- Work Light
- Stack Light (3 colors)
- Retention Knobs
- Surround Tool Coolant (On Spindle)
- Spindle Taper Cleaner
- Remote MPG (Option for Heidenhain)
- Ethernet Connection
- Automatic Power Off
- Cutter Air Blast (Spindle side)
- Thermal Compensation (Heidenhain)

OPTIONAL FEATURES

- 4th Axis Pre-wiring
- 4th Axis Drive Package
- 5th Axis Drive Package (4+1)
- Spare M-Codes (8)
- Part / Tool Probe (Wireless)
- (OMP 40-2 + OTS with OMI-2T)
- Linear Optical Scales (X/Y/Z Axes)
- Column Riser 150 mm
- Power Case Chiller
- External Spindle Surround Coolant
- Coolant Chip Flush / Coolant Wash Gun (Needs Chip Flush)
- Chip Conveyor : Hinge Type / Scraper Type
- Coolant Through Spindle , 280 psi (20 Bar)
- Tool Magazine Autodoor
- Automatic central grease lubrication (X/Y/Z Axes)
- Spindle Oil Chiller
- AICCI (200 Block) (Fanuc)

HARDINGE WORLDWIDE

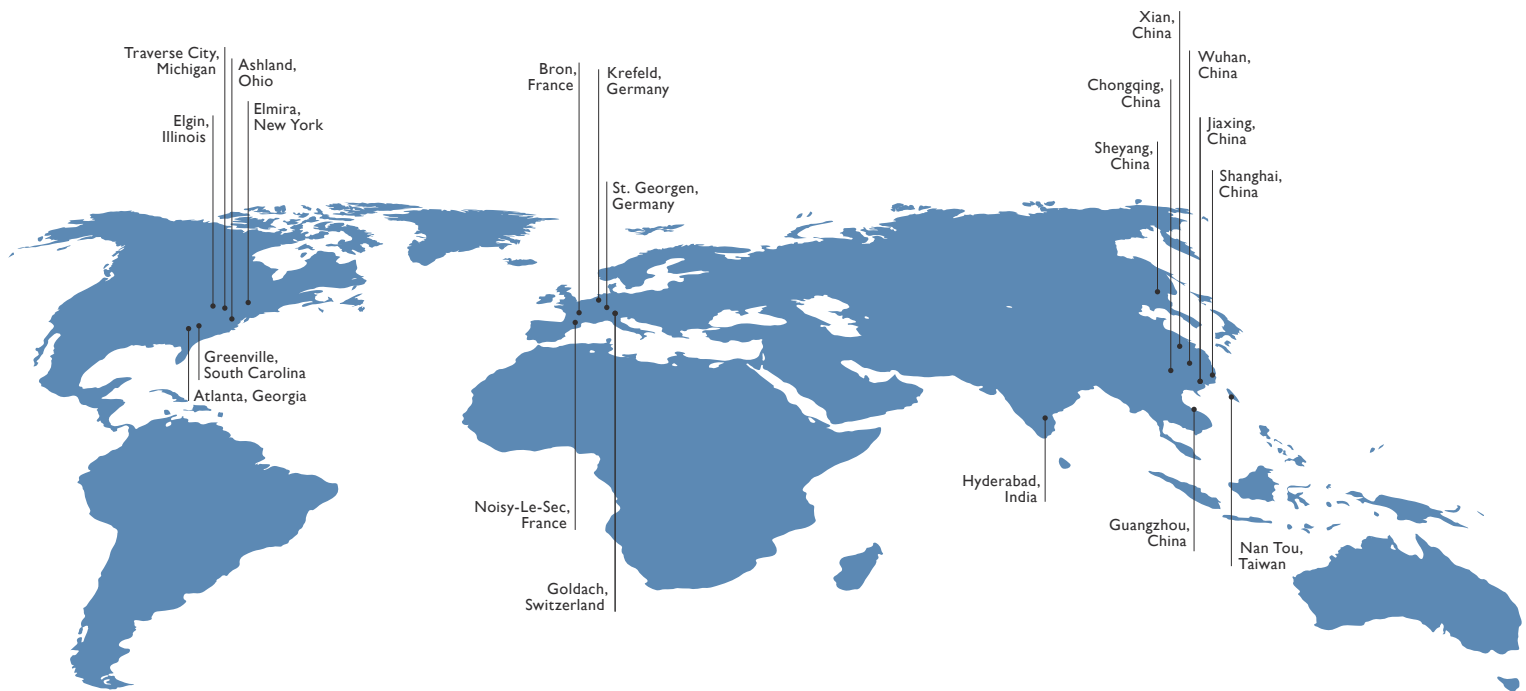

Hardinge is a leading international provider of advanced metal-cutting solutions. We provide a full spectrum of highly reliable CNC turning, milling, grinding, and honing machines as well as technologically advanced workholding accessories.

The diverse products we offer enable us to support a variety of market applications in industries including aerospace, agricultural, automotive, construction, consumer products, defense, energy, medical, technology, transportation and more.

We've developed a strong global presence with manufacturing operations in North America, Europe, and Asia. Hardinge applies its engineering and applications expertise to provide your company with the right machine tool solution and support every time.

AMERICAS

GEORGIA
Hardinge Corporate
79 W Paces Ferry Rd, 2F
Atlanta, GA 30305
P. +800.843.8801

ILLINOIS
Hardinge
1755 Britannia Dr
Unit 1A
Elgin, IL 60124
P. +800.843.8801

MICHIGAN
Forkardt
2155 Traversefield Dr
Traverse City, MI 49686
P. +800.544.3823
E. tcsales@forkardt.com

NEW YORK
Hardinge
1 Hardinge Drive
Elmira, NY 14903
P. +800.843.8801
E. info@hardinge.com

OHIO
Ohio Tool Works
1374 Enterprise Parkway (TR 743)
Ashland, OH 44805
P. +419.281.3700
E. sales@ohiotoolworks.com

EUROPE

SCHWEIZ
Hardinge Kellenberger AG
Thannäckerstrasse 22
CH-9403 Goldach
P. +41 71 2429111
E. info@kellenberger.net

DEUTSCHLAND
Hardinge GmbH
Fichtenhain A 13c
47807 Krefeld
P. +49 2151 496490
E. info@hardinge-gmbh.de

J.G. Weisser Söhne GmbH
Johann-Georg-Weisser-Straße 1
78112 St. Georgen
P. +49 7724 881-0
E. info@weisser-web.com

FRANKREICH
Jones & Shipman SARL
8 Allee des Ginkgos
BP 112-69672
Bron Cedex, France
P. +33 472 812660

ASIA

CHINA
Hardinge Machine
(Shanghai) Co. Ltd.
1388 East Kangqiao Road
Pudong, Shanghai 201319
P. +86 21 3810 8686

TAIWAN
Hardinge Machine Tools
B.V., Taiwan Branch
No.11,Tzu Li 3rd Rd.,
Nantou City, 540 Taiwan
P. +886 49 2260 536
E. cs@hardinge.com.tw